



نگهداشت و افزایش تولید میدان نفتی بینک
فعالیت های روزمینی در بسته های کاری تحت الارض
عمومی و مشترک



شماره پیمان:

053 - 073 - 9184

ISOLATION PHILOSOPHY

نسخه	سریال	نوع مدرک	رشته	تسهیلات	صادر کننده	بسته کاری	پروژه
D02	0004	PH	PR	110	PEDCO	SSGRL	BK

شماره صفحه: 1 از 17

طرح نگهداشت و افزایش تولید 27 مخزن

ISOLATION PHILOSOPHY

نگهداشت و افزایش تولید میدان نفتی بینک

Rev.	Date	Purpose of Issue/Status	Prepared by:	Checked by:	Approved by:	CLIENT Approval
D02	JAN.2022	AFD	M.Aryafar	M.Fakharian	M.Mehrshad	
D01	DEC.2022	IFA	M.Aryafar	M.Fakharian	M.Mehrshad	
D00	Nov. 2021	IFC	M.Aryafar	M.Fakharian	M.Mehrshad	

Class:2

CLIENT Doc. Number: F0Z-707345

Status:

IDC: Inter-Discipline Check
IFC: Issued For Comment
IFA: Issued For Approval
AFD: Approved For Design
AFC: Approved For Construction
AFP: Approved For Purchase
AFQ: Approved For Quotation
IFI: Issued For Information
AB-R: As-Built for CLIENT Review
AB-A: As-Built -Approved



نگهداشت و افزایش تولید میدان نفتی بینک
 فعالیت های روز زمینی در بسته های کاری تحت الارض
 عمومی و مشترک



شماره پیمان:

053 - 073 - 9184

ISOLATION PHILOSOPHY



نسخه	سریال	نوع مدرک	رشته	تسهیلات	صادر کننده	بسته کاری	پروژه
D02	0004	PH	PR	110	PEDCO	SSGRL	BK

شماره صفحه : 2 از 17

REVISION RECORD SHEET



PAGE	D00	D01	D02	D03	D04
1	X	X	X		
2	X	X	X		
3	X				
4	X				
5	X				
6	X				
7	X				
8	X				
9	X				
10	X				
11	X				
12	X				
13	X				
14	X				
15	X				
16	X				
17	X				
18					
19					
20					
21					
22					
23					
24					
25					
26					
27					
28					
29					
30					
31					
32					
33					
34					
35					
36					
37					
38					
39					
40					
41					
42					
43					
44					
45					
46					
47					
48					
49					
50					
51					
52					
53					
54					
55					
56					
57					
58					
59					
60					
61					
62					
63					
64					
65					

PAGE	D00	D01	D02	D03	D04
66					
67					
68					
69					
70					
71					
72					
73					
74					
75					
76					
77					
78					
79					
80					
81					
82					
83					
84					
85					
86					
87					
88					
89					
90					
91					
92					
93					
94					
95					
96					
97					
98					
99					
100					
101					
102					
103					
104					
105					
106					
107					
108					
109					
110					
111					
112					
113					
114					
115					
116					
117					
118					
119					
120					
121					
122					
123					
124					
125					
126					
127					
128					
129					
130					

 <p>NISOC</p>	<p>نگهداشت و افزایش تولید میدان نفتی بینک فعالیت های روزمینی در بسته های کاری تحت الارض عمومی و مشترک</p>	 <p>شرکت توسعه و پتروایران</p>																
<p>شماره پیمان: 053 – 073 – 9184</p>	<p style="text-align: center;">ISOLATION PHILOSOPHY</p> <table border="1" style="width: 100%; text-align: center;"> <tr> <td>پروژه</td> <td>بسته کاری</td> <td>صادر کننده</td> <td>تسهیلات</td> <td>رشته</td> <td>نوع مدرک</td> <td>سریال</td> <td>نسخه</td> </tr> <tr> <td>BK</td> <td>SSGRL</td> <td>PEDCO</td> <td>110</td> <td>PR</td> <td>PH</td> <td>0004</td> <td>D02</td> </tr> </table>	پروژه	بسته کاری	صادر کننده	تسهیلات	رشته	نوع مدرک	سریال	نسخه	BK	SSGRL	PEDCO	110	PR	PH	0004	D02	<p style="text-align: center;">شماره صفحه : 3 از 17</p>
پروژه	بسته کاری	صادر کننده	تسهیلات	رشته	نوع مدرک	سریال	نسخه											
BK	SSGRL	PEDCO	110	PR	PH	0004	D02											

CONTENTS

1.0	INTRODUCTION	4
2.0	SCOPE	5
3.0	NORMATIVE REFERENCES.....	5
3.1	LOCAL CODES AND STANDARDS.....	5
3.2	INTERNATIONAL CODES AND STANDARDS	5
3.3	THE PROJECT DOCUMENTS.....	5
3.4	ENVIRONMENTAL DATA	5
3.5	ABBREVIATIONS	6
4.0	PROCESS DEFINITIONS	6
4.1	HIGH VAPOR PRESSURE SERVICE	6
4.2	HIGH H ₂ S RISK AREAS.....	6
5.0	ISOLATION METHODS AND APPLICATION.....	6
5.1	POSITIVE ISOLATION.....	7
5.2	GENERAL ISOLATION	7
5.3	GENERAL RECOMMENDATION.....	8
6.0	ISOLATION PHILOSOPHIES	9
6.1	PLANT MAINTENANCE SYSTEMS	9
6.2	ISOLATION FOR SHUTDOWN MAINTENANCE	9
6.3	ISOLATION AT UNIT BATTERY LIMIT.....	9
6.4	ISOLATION AT PACKAGE UNITS.....	12
7.0	ISOLATION FOR PERSONNEL PROTECTION	13
8.0	SPECIFIC ISOLATION REQUIREMENT BY EQUIPMENT	13
8.1	ISOLATION FOR RELIEF VALVES.....	13
8.2	ISOLATION OF START-UP BYPASS LINES DURING NORMAL OPERATION.....	16
8.3	ISOLATION OF UTILITIES FROM PROCESS SYSTEMS.....	17

 <p>NISOC</p>	<p>نگهداشت و افزایش تولید میدان نفتی بینک فعالیت های روزمینی در بسته های کاری تحت الارض عمومی و مشترک</p>																	
<p>شماره پیمان: 053 – 073 – 9184</p>	<p>ISOLATION PHILOSOPHY</p> <table border="1" style="width: 100%; border-collapse: collapse;"> <tr> <td style="width: 10%;">پروژه</td> <td style="width: 10%;">بسته کاری</td> <td style="width: 10%;">صادر کننده</td> <td style="width: 10%;">تسهیلات</td> <td style="width: 10%;">رشته</td> <td style="width: 10%;">نوع مدرک</td> <td style="width: 10%;">سریال</td> <td style="width: 10%;">نسخه</td> </tr> <tr> <td>BK</td> <td>SSGRL</td> <td>PEDCO</td> <td>110</td> <td>PR</td> <td>PH</td> <td>0004</td> <td>D02</td> </tr> </table>	پروژه	بسته کاری	صادر کننده	تسهیلات	رشته	نوع مدرک	سریال	نسخه	BK	SSGRL	PEDCO	110	PR	PH	0004	D02	<p>شماره صفحه : 4 از 17</p>
پروژه	بسته کاری	صادر کننده	تسهیلات	رشته	نوع مدرک	سریال	نسخه											
BK	SSGRL	PEDCO	110	PR	PH	0004	D02											

1.0 INTRODUCTION

Binak oilfield in Bushehr province is a part of the southern oilfields of Iran, is located 20 km northwest of Genaveh city.



With the aim of increasing production of oil from Binak oilfield, an EPC/EPD Project has been defined by NIOC/NISOC and awarded to Petro Iran Development Company (PEDCO). Also PEDCO (as General Contractor) has assigned the EPC-packages of the Project to "Hirgan Energy - Design and Inspection" JV.

As a part of the Project, construction of well location, access roads, wellhead facilities for 6 new wells (with electric power supply for 2 of them) and required modifications on 4 workover wells (with electric power supply) shall be done. In addition, construction of 6 new flowlines from new wells to Binak B/C unit (with extension of relevant manifold) are in the Project scope of work

GENERAL DEFINITION

The following terms shall be used in this document.

CLIENT:	National Iranian South Oilfields Company (NISOC)
PROJECT:	Binak Oilfield Development – Construction of New Well Locations, Modifications on Workover Wells, Wellhead Facilities, Electrification Facilities, Flowlines and Extension of Binak B/C Manifold
EPD/EPC CONTRACTOR (GC):	Petro Iran Development Company (PEDCO)
EPC CONTRACTOR:	Joint Venture of : Hirgan Energy – Design & Inspection (D&I) Companies
VENDOR:	The firm or person who will fabricate the equipment or material.
EXECUTOR:	Executor is the party which carries out all or part of construction and/or commissioning for the project.
THIRD PARTY INSPECTOR (TPI):	The firm appointed by EPD/EPC CONTRACTOR (GC) and approved by CLIENT (in writing) for the inspection of goods.
SHALL:	Is used where a provision is mandatory.
SHOULD:	Is used where a provision is advisory only.
WILL:	Is normally used in connection with the action by CLIENT rather than by an EPC/EPD CONTRACTOR, supplier or VENDOR.
MAY:	Is used where a provision is completely discretionary.

	<p>نگهداشت و افزایش تولید میدان نفتی بینک</p> <p>فعالیت های روزمینی در بسته های کاری تحت الارض</p> <p>عمومی و مشترک</p>																	
شماره پیمان: 053 – 073 – 9184	ISOLATION PHILOSOPHY <table border="1" style="width: 100%; text-align: center;"> <tr> <td>پروژه</td> <td>بسته کاری</td> <td>صادر کننده</td> <td>تسهیلات</td> <td>رشته</td> <td>نوع مدرک</td> <td>سریال</td> <td>نسخه</td> </tr> <tr> <td>BK</td> <td>SSGRL</td> <td>PEDCO</td> <td>110</td> <td>PR</td> <td>PH</td> <td>0004</td> <td>D02</td> </tr> </table>	پروژه	بسته کاری	صادر کننده	تسهیلات	رشته	نوع مدرک	سریال	نسخه	BK	SSGRL	PEDCO	110	PR	PH	0004	D02	شماره صفحه : 5 از 17
پروژه	بسته کاری	صادر کننده	تسهیلات	رشته	نوع مدرک	سریال	نسخه											
BK	SSGRL	PEDCO	110	PR	PH	0004	D02											

2.0 SCOPE

The purpose of this document is to provide safe and consistent method for the isolation of process equipment prior to and during maintenance / modification / repair.

This philosophy covers the flow lines and transfer lines. The wellhead flow line wing valve and upstream isolation including wellhead choke valve are outside the scope of this philosophy, as these are to be supplied by sub-surface department. The philosophy covers process and utility pipe work but specifically excludes isolation requirements for instrumentation.

3.0 NORMATIVE REFERENCES

3.1 LOCAL CODES AND STANDARDS

- IPS -E-PR-230 Engineering Standard for Piping & Instrumentation Diagram (P&IDS), First Revision, July 2009
- IPS-E-PI-240 Engineering Standard for Plant Piping Systems
- IPS-D-PI-119 Pressure Blind Details

3.2 INTERNATIONAL CODES AND STANDARDS



- API STD 521 Pressure-relieving and Depressuring Systems, 6th Edition
- API STD 520, Part 1 Sizing, Selection, and Installation of Pressure-relieving Devices, Part I - Sizing and Selection, 9th Edition
- API STD 607 Fire Test for Soft-Seated Quarter-turn Valves", Fourth Edition, 1998

3.3 THE PROJECT DOCUMENTS

For each plant defined by NISOC within project scope of work, corresponding documents (P&IDs, Design Basis, Process design criteria, ESD Philosophy) shall be used as reference for using this document.

3.4 ENVIRONMENTAL DATA

Refer to "Process Basis of Design; Doc. No. BK-00-HD-000-PR-DB-0001".

	<p>نگهداشت و افزایش تولید میدان نفتی بینک فعالیت های روزمینی در بسته های کاری تحت الارض</p> <p>عمومی و مشترک</p>																	
شماره پیمان: 053 – 073 – 9184	ISOLATION PHILOSOPHY <table border="1" style="width: 100%; border-collapse: collapse;"> <tr> <td style="width: 10%;">پروژه</td> <td style="width: 10%;">بسته کاری</td> <td style="width: 10%;">صادر کننده</td> <td style="width: 10%;">تسهیلات</td> <td style="width: 10%;">رشته</td> <td style="width: 10%;">نوع مدرک</td> <td style="width: 10%;">سریال</td> <td style="width: 10%;">نسخه</td> </tr> <tr> <td>BK</td> <td>SSGRL</td> <td>PEDCO</td> <td>110</td> <td>PR</td> <td>PH</td> <td>0004</td> <td>D02</td> </tr> </table>	پروژه	بسته کاری	صادر کننده	تسهیلات	رشته	نوع مدرک	سریال	نسخه	BK	SSGRL	PEDCO	110	PR	PH	0004	D02	شماره صفحه : 6 از 17
پروژه	بسته کاری	صادر کننده	تسهیلات	رشته	نوع مدرک	سریال	نسخه											
BK	SSGRL	PEDCO	110	PR	PH	0004	D02											

3.5 ABBREVIATIONS

CSC	Car Sealed Closed
CSO	Car Sealed Open
DBB	Double block and bleed
LC	Locked Closed
LO	Locked Open
RV	Fails Closed Relief Valve
EDV/BDV	Emergency Depressuring Valve
ESDV	Emergency Shutdown Valve

4.0 PROCESS DEFINITIONS

4.1 HIGH VAPOR PRESSURE SERVICE

High vapor pressure service must be considered for all hydrocarbons with a RVP equal or above 12psia.

4.2 HIGH H₂S RISK AREAS



High H₂S risk areas are defined as those where the process contain toxic gases with H₂S partial pressure exceeding 1 Bara and liquids in equilibrium with such gases.

5.0 ISOLATION METHODS AND APPLICATION

All isolation methods can fail (even positive isolations – particularly during installation and plant reinstatement activities). The potential for human failure is a major factor affecting the overall reliability of an isolation method. The performance of an isolation depends not only on the integrity of the isolation hardware, but also on the adequacy of the arrangements to identify each isolation point, secure the isolation, prove/monitor the isolation and maintain overall control of the work.

The methods of isolation provided are divided into two categories:

1. Positive Isolation: where no leakage can be tolerated; for example entry into vessels.
2. For less critical duties than the clause (1); for example when isolation is required for a short period and to enable positive isolation to be affected i.e. blinding device to be inserted.

	<p>نگهداشت و افزایش تولید میدان نفتی بینک فعالیت های روزمینی در بسته های کاری تحت الارض عمومی و مشترک</p>																	
شماره پیمان: 053 – 073 – 9184	ISOLATION PHILOSOPHY <table border="1" style="width: 100%; border-collapse: collapse;"> <tr> <td style="width: 10%;">پروژه</td> <td style="width: 10%;">بسته کاری</td> <td style="width: 10%;">صادر کننده</td> <td style="width: 10%;">تسهیلات</td> <td style="width: 10%;">رشته</td> <td style="width: 10%;">نوع مدرک</td> <td style="width: 10%;">سریال</td> <td style="width: 10%;">نسخه</td> </tr> <tr> <td>BK</td> <td>SSGRL</td> <td>PEDCO</td> <td>110</td> <td>PR</td> <td>PH</td> <td>0004</td> <td>D02</td> </tr> </table>	پروژه	بسته کاری	صادر کننده	تسهیلات	رشته	نوع مدرک	سریال	نسخه	BK	SSGRL	PEDCO	110	PR	PH	0004	D02	شماره صفحه : 7 از 17
پروژه	بسته کاری	صادر کننده	تسهیلات	رشته	نوع مدرک	سریال	نسخه											
BK	SSGRL	PEDCO	110	PR	PH	0004	D02											

5.1 POSITIVE ISOLATION

5.1.1 Definition

The purpose of positive isolation is to cut the continuity of a circuit conveying a fluid both liquid and gas.

This is achieved with one of the following techniques:

- Taking off piping removable section and tapping open lines with blind flanges,
- Installation of blind spacers between flanges,

In case it is not practical to provide spectacle blind or spade, positive isolation shall be achieved by a removable spool piece (RS).

5.1.2 Requirements

Design of new plant should include facilities for positive isolation (including the valved isolation to install the positive isolation) in the following situations:

- To permit isolation of vessels and tanks which have man ways or manholes.
- For isolation of toxic services.
- To control segregation of parts of the plant which, in alternative operating modes, might otherwise be exposed to overpressure conditions. This applies where it is not reasonably practicable for the installed safety systems to protect all foreseeable operating configurations, for example the separation of a high-pressure plant from its drainage system.

5.2 GENERAL ISOLATION



General isolation shall be provided by double block and bleed, double block without intermediate bleed, single block and bleed or isolation with single block valve.

This kind of isolation is used to safe achievement/ install of positive isolation or as primary isolation if it is considered safe enough or to maintain the pressure in confined space.

5.2.1 Isolation with a Single Valve (SV)

Isolation against non-sour hydrocarbon systems as well as low H₂S risk systems can be accomplished with a single isolation valve.

Also single isolation valve shall be provided for isolation requirements in all Non-Hydrocarbon systems, i.e. Instrument Air, Utility Air, Utility Water, Potable Water, Inert Gas, etc.

 <p>NISOC</p>	<p>نگهداشت و افزایش تولید میدان نفتی بینک فعالیت های روزمینی در بسته های کاری تحت الارض عمومی و مشترک</p>																	
<p>شماره پیمان: 053 – 073 – 9184</p>	<p>ISOLATION PHILOSOPHY</p> <table border="1" style="width: 100%; border-collapse: collapse;"> <tr> <td style="width: 10%;">پروژه</td> <td style="width: 10%;">بسته کاری</td> <td style="width: 10%;">صادر کننده</td> <td style="width: 10%;">تسهیلات</td> <td style="width: 10%;">رشته</td> <td style="width: 10%;">نوع مدرک</td> <td style="width: 10%;">سریال</td> <td style="width: 10%;">نسخه</td> </tr> <tr> <td>BK</td> <td>SSGRL</td> <td>PEDCO</td> <td>110</td> <td>PR</td> <td>PH</td> <td>0004</td> <td>D02</td> </tr> </table>	پروژه	بسته کاری	صادر کننده	تسهیلات	رشته	نوع مدرک	سریال	نسخه	BK	SSGRL	PEDCO	110	PR	PH	0004	D02	<p>شماره صفحه : 8 از 17</p>
پروژه	بسته کاری	صادر کننده	تسهیلات	رشته	نوع مدرک	سریال	نسخه											
BK	SSGRL	PEDCO	110	PR	PH	0004	D02											

5.2.2 Double Block and Bleed (DBB)

This system consists of two valves; the space between those valves is an interconnecting piping spool fitted with a bleed connection as a vent/ drain.

For sweet service the bleed valve shall be routed out to the atmosphere (at safe location) and monitoring.

It is recommended to use double valves without a bleed valve mounted on the pipe work between them.

Areas where double block and bleed valves shall be specified include:

- Systems isolating high temperature fluids at or above auto ignition,
- Toxic service (where H₂S partial pressure is higher than 1 bara)
- Isolation between Metering System and Proving System,
- For High Pressure Services Over Design Pressure Of 38 barg, Or Where The Nature Of Liquid Requires It.

Distance between the two valves shall be minimized to reduce the volume to be vented or drained. In case of ice or hydrate formation, the valves shall be separated by 600 mm to reduce the risk of simultaneous obstruction of both valves by ice or hydrate formation.

If an ESD valve is part of the two valves, a manually operated three-way valve with a lock closed facility shall be provided for each actuator to enable the valve to be closed locally and be locked closed for operations/ maintenance purposes.

NOTE: Based on Basic Engineering Endorsement Report document “Doc. No. BK- GNRAL-PEDCO-000-PM-RT-0001-D02”HD-000-PR-DB-0001 “single isolation valve must be considered for isolation of all systems.

5.3 GENERAL RECOMMENDATION



A group of items containing no block valves in the interconnecting pipework may be considered as one item of equipment.

ESD valve in combination with a manual block valve can be considered as double block valve configuration.

All isolation valves shall be ball type for sour liquid hydrocarbon and gas services and should be gate type for sweet liquid hydrocarbon and generally liquid services.

Control valves shall not be used for isolation purposes.

Operated valves, which fail open, shall not be used as single isolation valves.

	<p>نگهداشت و افزایش تولید میدان نفتی بینک فعالیت های روزمینی در بسته های کاری تحت الارض عمومی و مشترک</p>																	
<p>شماره پیمان: 053 – 073 – 9184</p>	<p>ISOLATION PHILOSOPHY</p> <table border="1" style="width: 100%; border-collapse: collapse;"> <thead> <tr> <th>پروژه</th> <th>بسته کاری</th> <th>صادر کننده</th> <th>تسهیلات</th> <th>رشته</th> <th>نوع مدرک</th> <th>سریال</th> <th>نسخه</th> </tr> </thead> <tbody> <tr> <td>BK</td> <td>SSGRL</td> <td>PEDCO</td> <td>110</td> <td>PR</td> <td>PH</td> <td>0004</td> <td>D02</td> </tr> </tbody> </table>	پروژه	بسته کاری	صادر کننده	تسهیلات	رشته	نوع مدرک	سریال	نسخه	BK	SSGRL	PEDCO	110	PR	PH	0004	D02	<p>شماره صفحه : 9 از 17</p>
پروژه	بسته کاری	صادر کننده	تسهیلات	رشته	نوع مدرک	سریال	نسخه											
BK	SSGRL	PEDCO	110	PR	PH	0004	D02											

6.0 ISOLATION PHILOSOPHIES

6.1 PLANT MAINTENANCE SYSTEMS

The following units of the plant may be individually isolated for maintenance in accordance with the requirement set out in this document:

- Utility
- Flow Lines

6.2 ISOLATION FOR SHUTDOWN MAINTENANCE

Shutdown means that the Plant, Unit or System has been isolated and that it is at atmospheric pressure, drained, steamed out or purged and free of hydrocarbons or chemicals.

For the complete Unit shutdown, all the feeds, products and utility lines shall be isolated at the Unit battery limits. There must be provision made to do this.

For equipment isolation, more specific isolation needs to be made either during normal operation or on shutdown when this isolation is to remain in place after plant start-up.

The generic method identifies the system to be shut down and provides positive isolation. It is important that the isolation is positive and does not rely on valves alone, which may leak. A positive means of isolation with an insertion plate (standard), blank flange, removable spool, etc. is normally required.

6.3 ISOLATION AT UNIT BATTERY LIMIT

Blinds (spectacle) shall be fitted on all Battery Limit (BL) lines. At the blinding station, the block valve or valves shall be closed and the BL bleeder valve left open.

Typical sketches for general hydrocarbon, high vapor pressure fluids in two-way isolation are given in Figures 6.1 ~ 6.4 below.

Utility isolation is shown in Figures 6.5 and 6.6.



نگهداشت و افزایش تولید میدان نفتی بینک
 فعالیت های روز زمینی در بسته های کاری تحت الارض
 عمومی و مشترک



شماره پیمان: 053 - 073 - 9184	ISOLATION PHILOSOPHY							شماره صفحه : 10 از 17
	پروژه	بسته کاری	صادر کننده	تسهیلات	رشته	نوع مدرک	سریال	
	BK	SSGRL	PEDCO	110	PR	PH	0004	

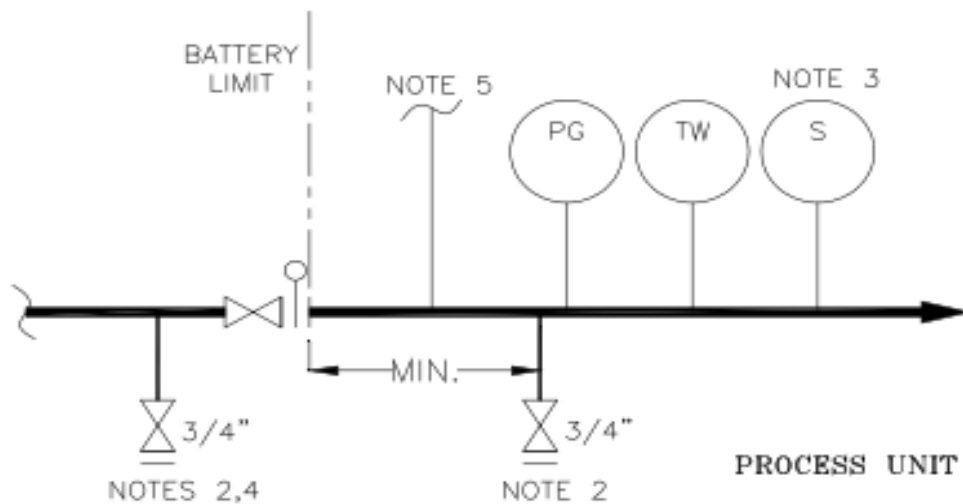

Figure 6.1: General Low Pressure Hydrocarbon Upstream Isolation (Note 1)

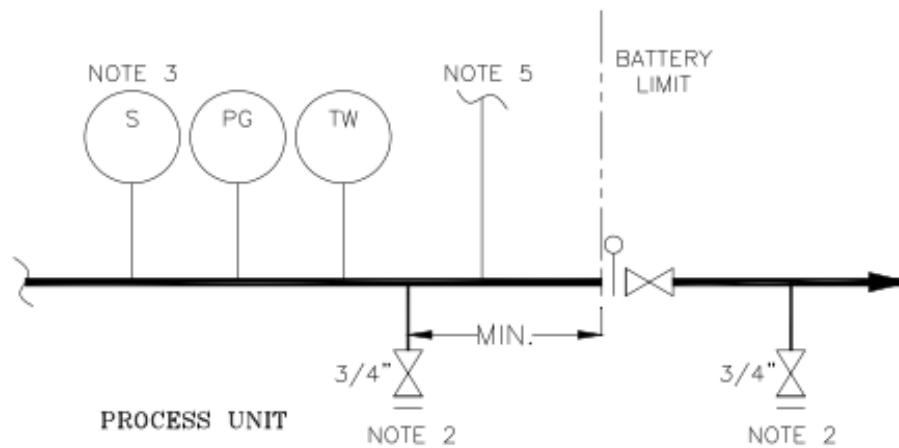

Figure 6.2: General Low Pressure Hydrocarbon Downstream Isolation (Note 1)



نگهداشت و افزایش تولید میدان نفتی بینک
 فعالیت های روزمینی در بسته های کاری تحت الارض
 عمومی و مشترک



شماره پیمان: 053 - 073 - 9184	ISOLATION PHILOSOPHY							شماره صفحه : 11 از 17
	پروژه	بسته کاری	صادر کننده	تسهیلات	رشته	نوع مدرک	سریال	
	BK	SSGRL	PEDCO	110	PR	PH	0004	D02

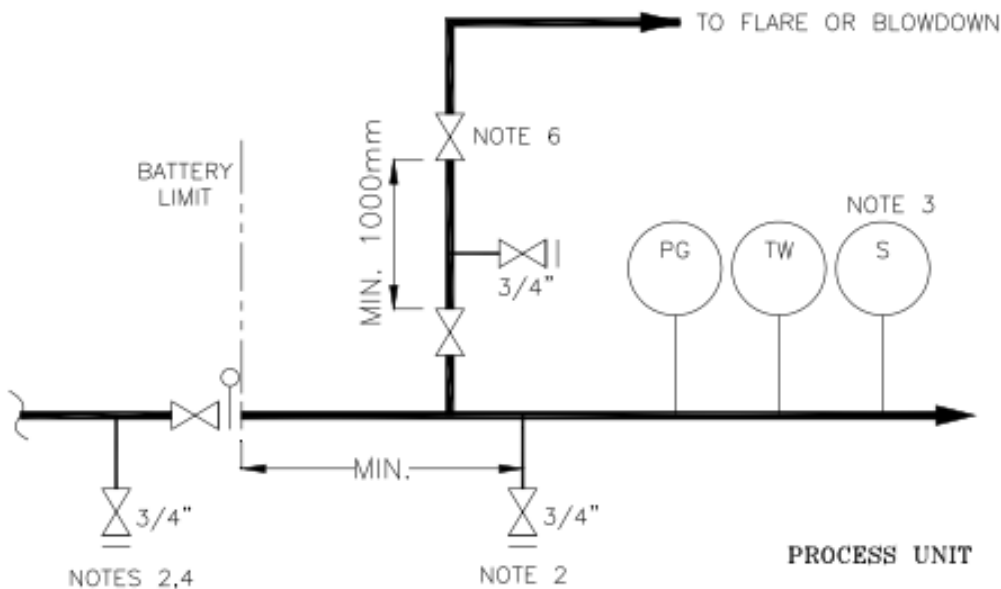

Figure 6.3: High Vapor Pressure Service Upstream Isolation (Note 1)

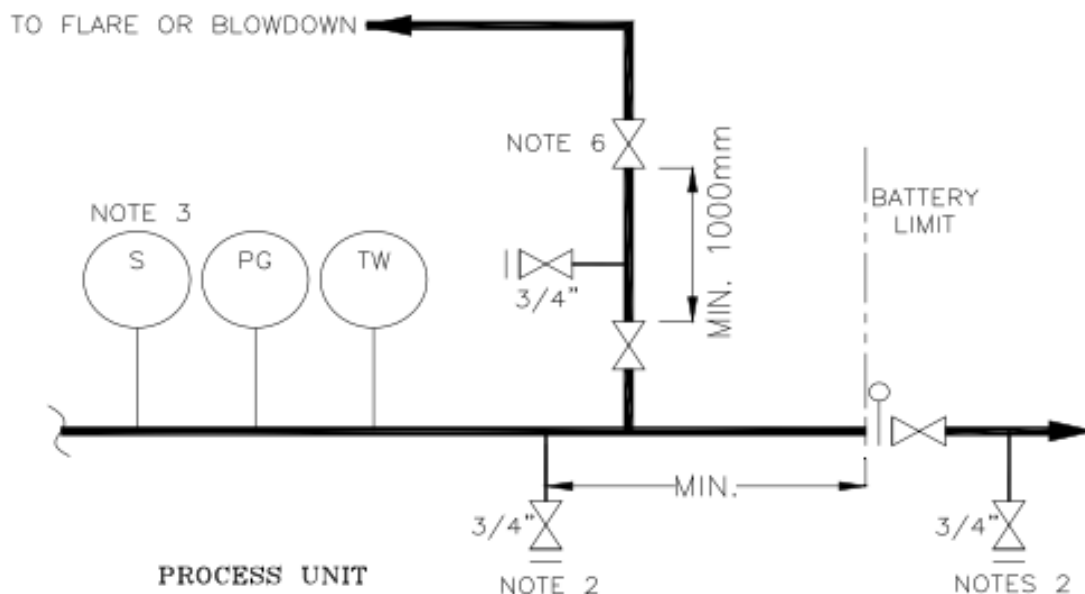



Figure 6.4: High Vapor Pressure Service Downstream Isolation (Note 1)

 <p>NISOC</p>	<p>نگهداشت و افزایش تولید میدان نفتی بینک فعالیت های روزمینی در بسته های کاری تحت الارض عمومی و مشترک</p>																	
<p>شماره پیمان: 053 - 073 - 9184</p>	<p>ISOLATION PHILOSOPHY</p> <table border="1" style="width: 100%; border-collapse: collapse;"> <thead> <tr> <th>پروژه</th> <th>بسته کاری</th> <th>صادر کننده</th> <th>تسهیلات</th> <th>رشته</th> <th>نوع مدرک</th> <th>سریال</th> <th>نسخه</th> </tr> </thead> <tbody> <tr> <td>BK</td> <td>SSGRL</td> <td>PEDCO</td> <td>110</td> <td>PR</td> <td>PH</td> <td>0004</td> <td>D02</td> </tr> </tbody> </table>	پروژه	بسته کاری	صادر کننده	تسهیلات	رشته	نوع مدرک	سریال	نسخه	BK	SSGRL	PEDCO	110	PR	PH	0004	D02	<p>شماره صفحه: 12 از 17</p>
پروژه	بسته کاری	صادر کننده	تسهیلات	رشته	نوع مدرک	سریال	نسخه											
BK	SSGRL	PEDCO	110	PR	PH	0004	D02											

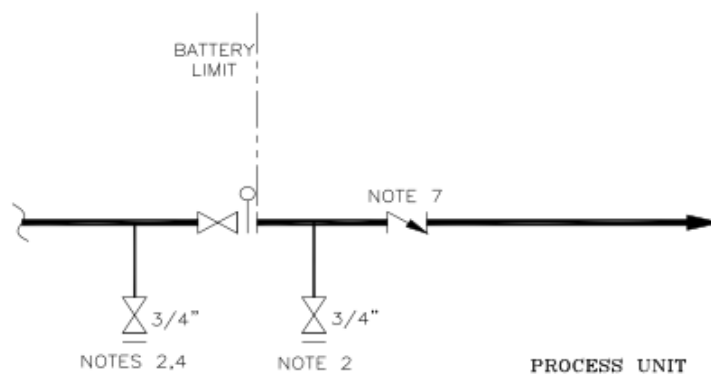

Figure 6.5: General Utility (Note 1)

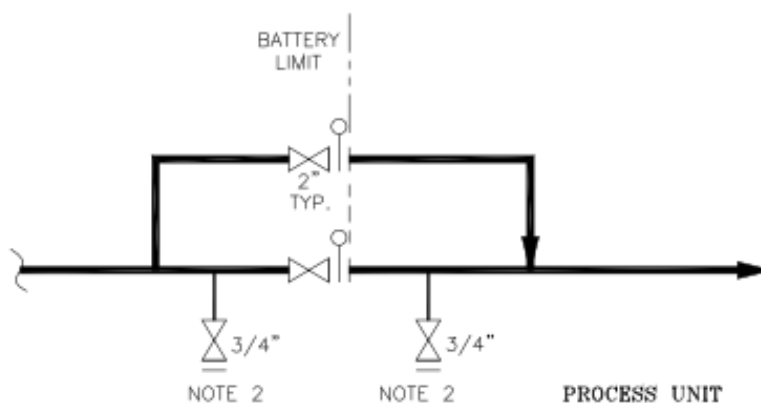



Figure 6.6: Steam Connections

Notes:

1. Double block and bleed valves may be required
2. Drain valve size is dependent on process line size. Normally 3/4" as defined on the P&ID.
3. Sample connection (if required).
4. Upstream valve may be required in some services.
5. To/from flushing oil, flare connections, etc., if required.
6. The need for BL depressurizing depends on the overall unit depressurizing philosophy.
7. NRV for Nitrogen service.

6.4 ISOLATION AT PACKAGE UNITS

All lines to and from VENDOR supplied package units shall have positive isolation.

 <p>NISOC</p>	<p>نگهداشت و افزایش تولید میدان نفتی بینک فعالیت های روزمینی در بسته های کاری تحت الارض عمومی و مشترک</p>																	
<p>شماره پیمان: 053 – 073 – 9184</p>	<p>ISOLATION PHILOSOPHY</p> <table border="1" style="width: 100%; border-collapse: collapse;"> <tr> <th>پروژه</th> <th>بسته کاری</th> <th>صادر کننده</th> <th>تسهیلات</th> <th>رشته</th> <th>نوع مدرک</th> <th>سریال</th> <th>نسخه</th> </tr> <tr> <td>BK</td> <td>SSGRL</td> <td>PEDCO</td> <td>110</td> <td>PR</td> <td>PH</td> <td>0004</td> <td>D02</td> </tr> </table>	پروژه	بسته کاری	صادر کننده	تسهیلات	رشته	نوع مدرک	سریال	نسخه	BK	SSGRL	PEDCO	110	PR	PH	0004	D02	<p>شماره صفحه : 13 از 17</p>
پروژه	بسته کاری	صادر کننده	تسهیلات	رشته	نوع مدرک	سریال	نسخه											
BK	SSGRL	PEDCO	110	PR	PH	0004	D02											

This may be provided within the VENDOR Package or shown on the CONTRACTOR P&IDs. The means of isolation should be reviewed during the Detailed Engineering phase to avoid duplication of valves.

7.0 ISOLATION FOR PERSONNEL PROTECTION

Entry by personnel to enclosed spaces shall be permitted only after positive isolation by installing blinds, blind flanges or other means at all connections, except those used for atmospheric ventilation.

Man-entry shall be by work permit only and the procedure and blind/ isolation lists shall be part of the work permit.

8.0 SPECIFIC ISOLATION REQUIREMENT BY EQUIPMENT

8.1 ISOLATION FOR RELIEF VALVES

8.1.1 Relief Valve for Services Other Than Thermal Relief

1. Relieving to Flare or Process

A Full bore block valve with an LO facility and bleed shall be specified for both inlet and outlet lines. (Double block and bleeds shall be used for services in section 5.2.2).

2. Relieving to Atmosphere at Safe Location

A full-bore block valve with an LO facility and bleed shall be specified only on the inlet line Provide separate tail pipes for each valve.

8.1.2 Relief Valve for Thermal Relief/Rupture Disk

1. Relieving to Flare or Process

A full bore block valve with an LO facility and bleed shall be specified for both inlet and outlet lines.

2. Relieving to Atmosphere at Safe Location

A single block valve with an LO facility and bleed shall be specified only on the inlet line Provide separate tail pipes for each valve.



نگهداشت و افزایش تولید میدان نفتی بینک
 فعالیت های روزمینی در بسته های کاری تحت الارض
 عمومی و مشترک



شماره پیمان: 053 - 073 - 9184	ISOLATION PHILOSOPHY							شماره صفحه : 14 از 17
	پروژه	بسته کاری	صادر کننده	تسهیلات	رشته	نوع مدرک	سریال	
	BK	SSGRL	PEDCO	110	PR	PH	0004	

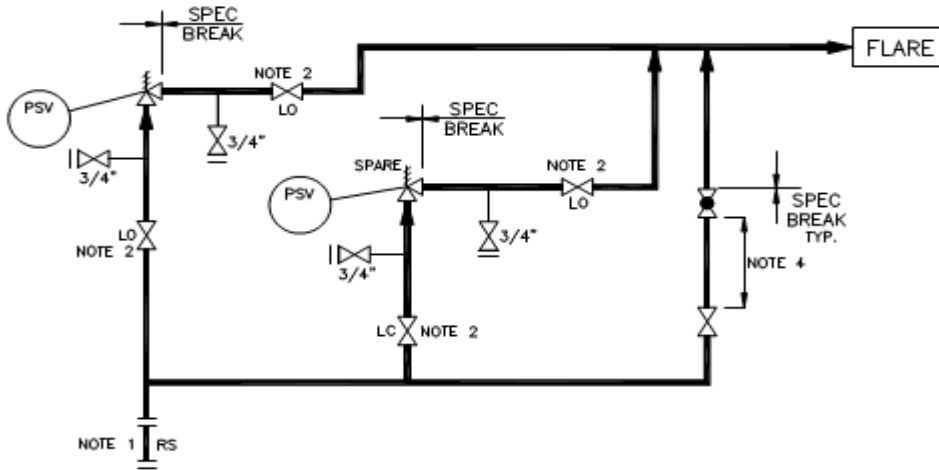

Figure 8.1: Services other than Thermal Relief- Closed Relief System

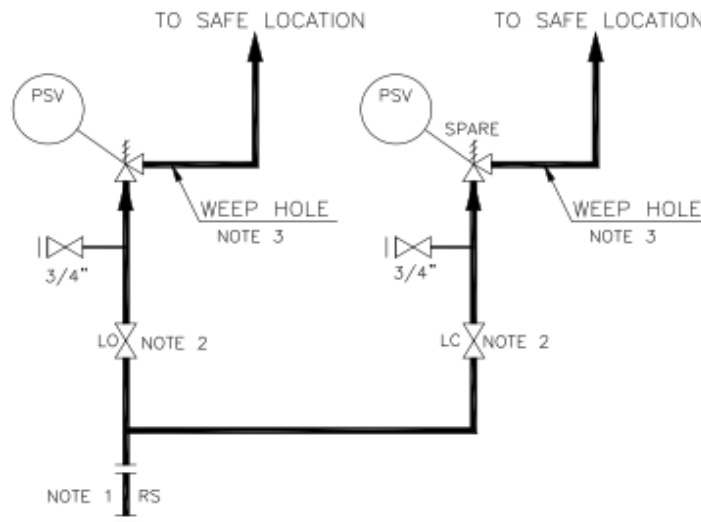

Figure 8.2: Services other than Thermal Relief- Open Relief System



نگهداشت و افزایش تولید میدان نفتی بینک
 فعالیت های روزمینی در بسته های کاری تحت الارض
 عمومی و مشترک



شماره پیمان:
 053 - 073 - 9184

ISOLATION PHILOSOPHY							
پروژه	بسته کاری	صادر کننده	تسهیلات	رشته	نوع مدرک	سریال	نسخه
BK	SSGRL	PEDCO	110	PR	PH	0004	D02

شماره صفحه: 15 از 17

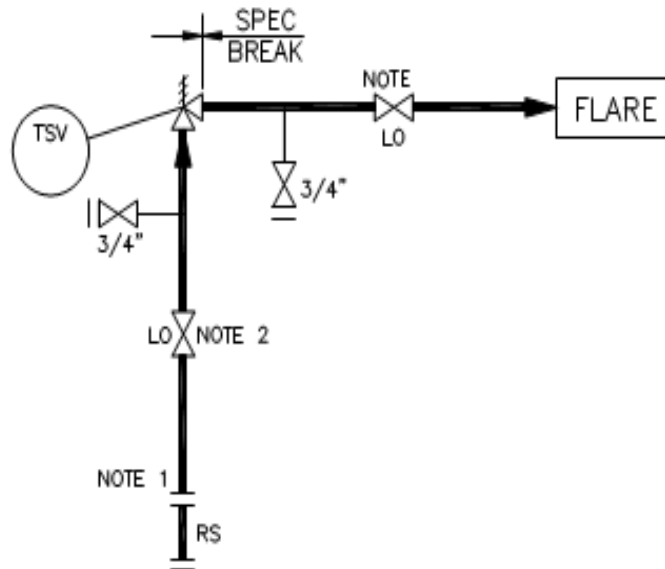

Figure 8.3: Thermal Relief- Closed Relief System

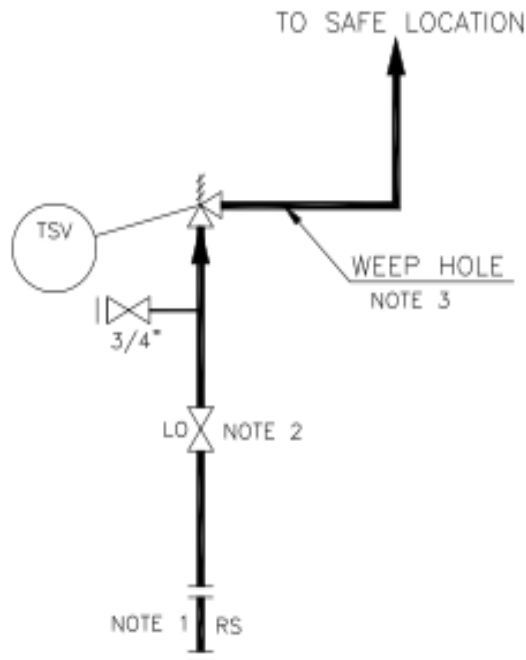



Figure 8.4: Thermal Relief - Open Relief System

 <p>NISOC</p>	<p>نگهداشت و افزایش تولید میدان نفتی بینک فعالیت های روزمینی در بسته های کاری تحت الارض عمومی و مشترک</p>																	
<p>شماره پیمان: 053 – 073 – 9184</p>	<p>ISOLATION PHILOSOPHY</p> <table border="1" style="width: 100%; border-collapse: collapse;"> <tr> <td style="width: 10%;">پروژه</td> <td style="width: 10%;">بسته کاری</td> <td style="width: 10%;">صادر کننده</td> <td style="width: 10%;">تسهیلات</td> <td style="width: 10%;">رشته</td> <td style="width: 10%;">نوع مدرک</td> <td style="width: 10%;">سریال</td> <td style="width: 10%;">نسخه</td> </tr> <tr> <td>BK</td> <td>SSGRL</td> <td>PEDCO</td> <td>110</td> <td>PR</td> <td>PH</td> <td>0004</td> <td>D02</td> </tr> </table>	پروژه	بسته کاری	صادر کننده	تسهیلات	رشته	نوع مدرک	سریال	نسخه	BK	SSGRL	PEDCO	110	PR	PH	0004	D02	<p>شماره صفحه : 16 از 17</p>
پروژه	بسته کاری	صادر کننده	تسهیلات	رشته	نوع مدرک	سریال	نسخه											
BK	SSGRL	PEDCO	110	PR	PH	0004	D02											

Notes:

1. From vessel or from piping on vessel without intervening valves.
2. Double block valve (without intermediate bleed and pressure indicator) shall be used for applications mentioned in Section 5.2.2.
3. Give consideration to whether condensation could occur e.g. in steam service if valve leaks badly, very hot water will come from the drain.
4. For wet and LPG service, a minimum spacing of 600 mm shall be specified between isolating and globe valves in order to avoid freezing.

8.1.3 Bypass Line

A bypass line around the relief valve(s) with a single isolation valve shall be specified only where there is a requirement to vent the gas in the system to flare and no other connection to flare is provided nearby. For wet and LPG service, a minimum spacing of 600 mm shall be specified between isolating and globe valves in order to avoid freezing.



8.1.4 Bleed Valves/ Weep Holes

Bleed valve shall be provided on the Relief Valve arrangement. Any requirement to vent at a safe location shall be noted. Weep holes shall be provided for valves, relieving to atmosphere (to prevent rainwater accumulating), with shielding or diversion for personnel protection as necessary.

8.2 ISOLATION OF START-UP BYPASS LINES DURING NORMAL OPERATION

Isolation philosophies for start-up bypass lines during normal operations are as follows:

- Isolation is normally by valve closure for any lines to be used during normal operation, or in reaction to emergency conditions. The fluid remaining in the piping shall be left in-situ.
- If the fluid has a high pour point, the line should be either traced or provision made for the line to be flushed to stop and drained down.
- Thermal relieving facility may need to be provided for a liquid, if the line can be isolated and is heat traced.
- Where the line is used only for pre-start-up circulation and flushing, blind isolation should be provided for closure in normal operation (after depressurizing the line).
- A blind shall be installed where leakage through any start-up or bypass line can cause serious product contamination. Typically a blind inside double block and bleed arrangement.
- Temporary piping shall be removed.
- Swing elbows/removable spools may be employed, where practical.

	<p>نگهداشت و افزایش تولید میدان نفتی بینک فعالیت های روزمینی در بسته های کاری تحت الارض عمومی و مشترک</p>																	
شماره پیمان: 053 - 073 - 9184	ISOLATION PHILOSOPHY <table border="1" style="width: 100%; border-collapse: collapse;"> <tr> <td style="width: 10%;">پروژه</td> <td style="width: 10%;">بسته کاری</td> <td style="width: 10%;">صادر کننده</td> <td style="width: 10%;">تسهیلات</td> <td style="width: 10%;">رشته</td> <td style="width: 10%;">نوع مدرک</td> <td style="width: 10%;">سریال</td> <td style="width: 10%;">نسخه</td> </tr> <tr> <td>BK</td> <td>SSGRL</td> <td>PEDCO</td> <td>110</td> <td>PR</td> <td>PH</td> <td>0004</td> <td>D02</td> </tr> </table>	پروژه	بسته کاری	صادر کننده	تسهیلات	رشته	نوع مدرک	سریال	نسخه	BK	SSGRL	PEDCO	110	PR	PH	0004	D02	شماره صفحه : 17 از 17
پروژه	بسته کاری	صادر کننده	تسهیلات	رشته	نوع مدرک	سریال	نسخه											
BK	SSGRL	PEDCO	110	PR	PH	0004	D02											

8.3 ISOLATION OF UTILITIES FROM PROCESS SYSTEMS

Temporary piping/ hoses for steam out and purging should normally be used. If permanent connections are required, Figure 8.5 shall be followed.

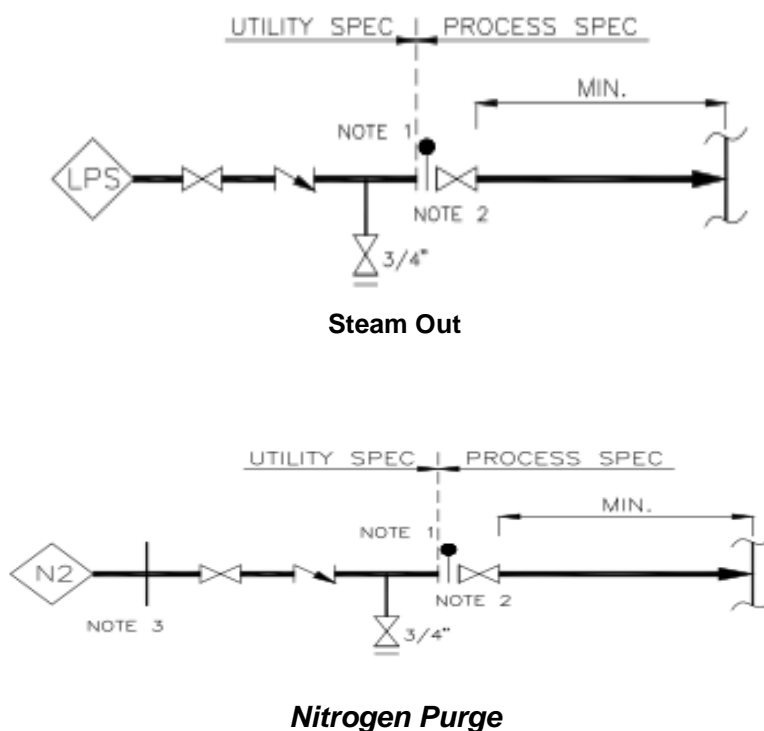

Figure 8.5: Utility Isolation

Notes:

1. The valve is to be included in the higher specification.
2. Double block valves may be provided. Valve closest to pipe or vessel to be locked closed.
3. A removable spool piece may be provided for maintenance isolation.