

1 PLAN
SC. 1:50

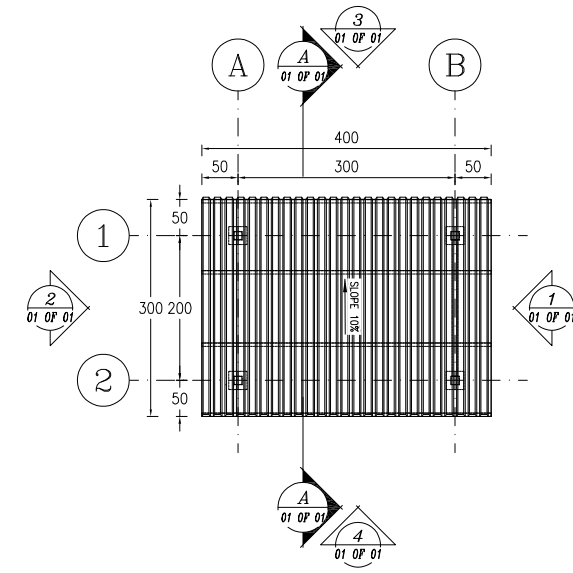

2 ROOF PLAN
SC. 1:50

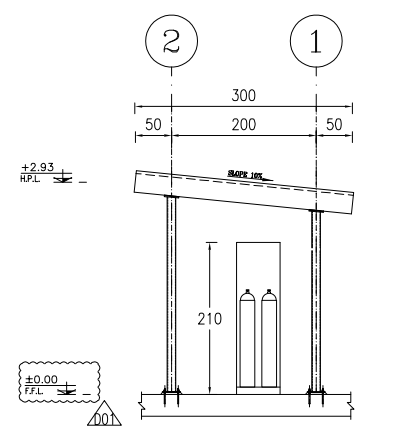

1 ELEVATION
SC. 1:50

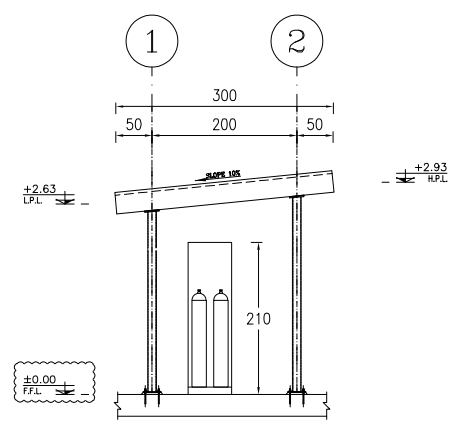

2 ELEVATION
SC. 1:50

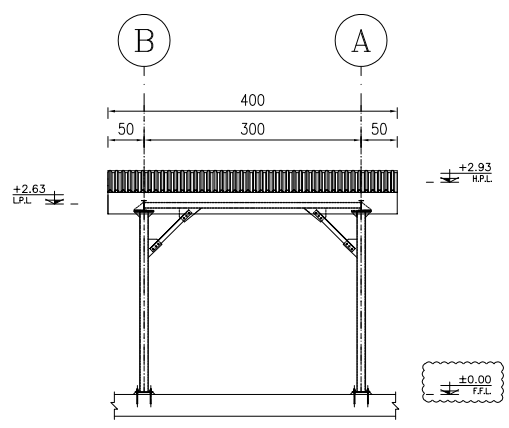

3 ELEVATION
SC. 1:50

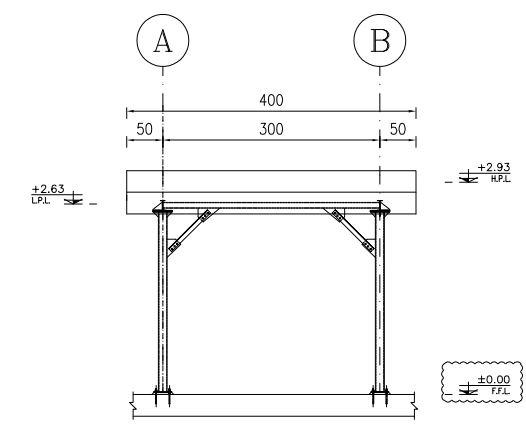

4 ELEVATION
SC. 1:50

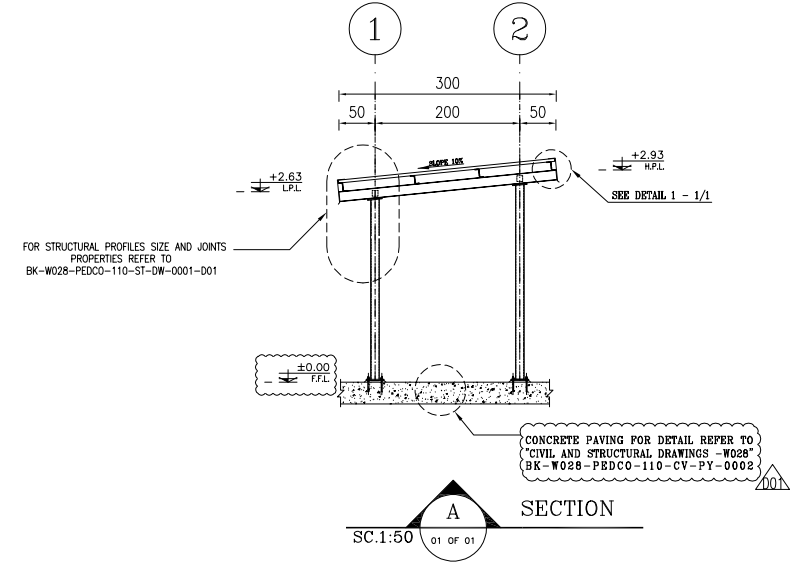

A SECTION
SC. 1:50

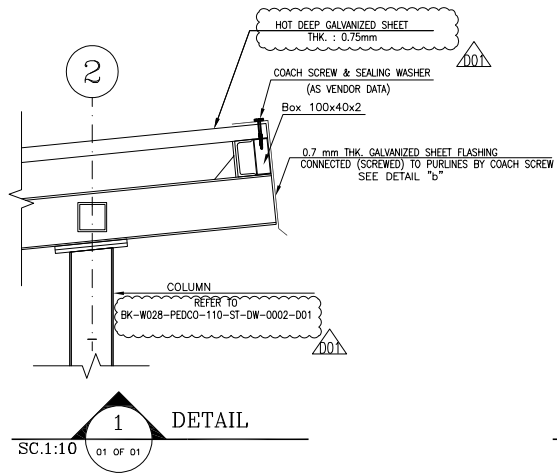

1 DETAIL
SC. 1:10

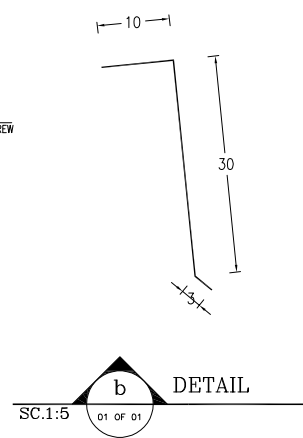

b DETAIL
SC. 1:5

- NOTES
- 1) DIMENSIONS ARE IN "cm" AND ELEVATIONS IN "m" UNLESS SPECIFIED.
 - 2) ALL COORDINATES ARE IN METERS EXCEPT OTHERWISE.
 - 3) ALL DIMENSIONS AND ELEVATIONS SHALL BE CHECKED BY THE CONTRACTOR PRIOR TO CONSTRUCTION.
 - 4) CONTRACTOR SHALL CHECK THE FOUNDATION DRAWING WITH ALL STRUCTURAL, MECHANICAL, INSTRUMENT, PIPING & ELECTRICAL DRAWINGS BEFORE CONSTRUCTION AND ANY REQUIRED MODIFICATIONS SHALL BE CONSIDERED WITH PRIOR CLIENT APPROVAL BEFORE CONSTRUCTION.
 - 5) ALL MATERIALS ARE SELECTED FROM THE HIGHEST QUALITY AND SHALL BE APPROVED BY THE CLIENT
 - 6) FINISH GRADING LEVEL (W028) ELEVATION = +31.05 m (GLOBAL) = ±0.00 (H.P.F.)

LEGEND

F.F.L.	FINISH FLOOR LEVEL
L.P.L.	LOWEST POINT OF LEVEL
H.P.L.	HIGHEST POINT OF LEVEL

REFERENCE DRAWING	DRG. No.
STRUCTURE DRAWING FOR WHCP/HPU SHELTER - W028	BK-W028-PEDCO-110-ST-DW-0001
PLOT PLAN DRAWING - W028	BK-W028-PEDCO-110-PI-DW-0001
GENERAL CIVIL LAYOUT - W028	BK-W028-PEDCO-110-CV-PY-0001
DATA SHEETS FOR WHCP/HPU - WELLHEADS	BK-SSREL-PEDCO-110-IN-DT-0001

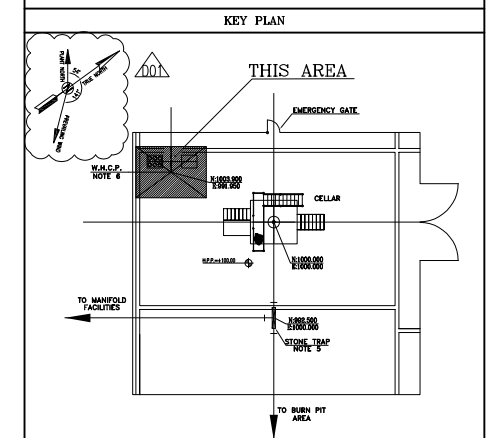

REV.	DATE	P.O.I.S	PREP.	CHK.	APP.	AUT.	DESCRIPTION	CHECKED	DATE	BY	DATE	BY	DATE
D01	APR.2023	APC	R.BELOUE	M.FAKHARIAN	M.Mehrshad	***							
D00	FEB.2022	IPC	R.BELOUE	M.FAKHARIAN	M.Mehrshad	***							

PROJECT NAME: BINAK OILFIELD DEVELOPMENT/SUB-SURFACE WORK PACKAGES W028 WELLHEAD FACILITIES

PROJECT NO.: 971020

EPC CONTRACTOR: HIRGAN ENERGY - DESIGN & INSPECTION COMPANIES

EPD/EPC CONTRACTOR (GC): PETROIRAN DEVELOPMENT COMPANY

DRAWING TITLE: ARCHITECTURAL DRAWING FOR WHCP/HPU SHELTER OF WELL PADS - W028 PLANS - ELEVATIONS - SECTION

NO CONSTRUCTION PERMITTED UNLESS DRAWING APPROVED

APPROVED FOR CONSTRUCTION	BY:	DATE:
---------------------------	-----	-------

SCALE	SIZE	DRAWING NO.	SHEET NO.	REV.	BUDGET REF.	LOCATION	SIZE	CLASS	SERIAL NO.	SHEET	REVISION
AS SHOWN	A1	BK-W028-PEDCO-110-AR-DW-0001	1 OF 1	D01	D53-073-9184	F	4	2	707546	1 OF 1	D01