



NISOC

نگهداشت و افزایش تولید میدان نفتی بینک
سطح الارض

احداث ردیف تراکم گاز در ایستگاه جمع آوری بینک



DATA SHEETS FOR ESD CONSOLE/ F&G MATRIX PANEL

شماره پیمان:

۰۵۳ - ۰۷۳ - ۹۱۸۴

پروژه

BK

بسته کاری

GCS

صادرکننده

PEDCO

تسهیلات

120

رشته

IN

نوع مدرک

DT

سریال

0017

نسخه

D02

شماره صفحه: ۱ از ۸

طرح نگهداشت و افزایش تولید ۲۷ مخزن

DATA SHEETS FOR ESD CONSOLE/ F&G MATRIX PANEL

نگهداشت و افزایش تولید میدان نفتی بینک

Rev.	Date	Purpose of Issue / Status	Prepared by:	Checked by:	Approved by:	CLIENT Approval
D02	NOV.2023	IFA	P.Hajisadeghi	M.Fakharian	S.Faramarzpour	
D01	DEC.2022	IFA	P.Hajisadeghi	M.Fakharian	M.Mehrshad	
D00	APR.2022	IFC	P.Hajisadeghi	M.Fakharian	M.Mehrshad	

Class: 1

CLIENT Doc. Number: F9Z-708937

status:

IDC: Inter-Discipline Check

IFC: Issued For Comment

IFA: Issued For Approval

AFD: Approved For Design

AFC: Approved For Construction

AFP: Approved For Purchase

AFQ: Approved For Quotation

IFI: Issued For Information

AB-R: As-Built for CLIENT Review

AB-A: As-Built -Approved



NISOC

نگهداشت و افزایش تولید میدان نفتی بینک
سطح الارض

احداث ردیف تراکم گاز در ایستگاه جمع آوری بینک



DATA SHEETS FOR ESD CONSOLE/ F&G MATRIX PANEL

شماره پیمان:

۰۵۳ - ۰۷۳ - ۹۱۸۴

نسخه	سریال	نوع مدرک	رشته	تسهیلات	صادرکننده	بسته کاری	پروژه
D02	0017	DT	IN	120	PEDCO	GCS	BK

شماره صفحه: ۲ از ۸

REVISION RECORD SHEET

Page	D00	D01	D02	D03	D04	Page	D00	D01	D02	D03	D04
1	X	X	X			65					
2	X	X	X			66					
3	X	X	X			67					
4	X	X	X			68					
5	X	X	X			69					
6	X	X	X			70					
7	X	X	X			71					
8		X	X			72					
9						73					
10						74					
11						75					
12						76					
13						77					
14						78					
15						79					
16						80					
17						81					
18						82					
19						83					
20						84					
21						85					
22						86					
23						87					
24						88					
25						89					
26						90					
27						91					
28						92					
29						93					
30						94					
31						95					
32						96					
33						97					
34						98					
35						99					
36						100					
37						101					
38						102					
39						103					
40						104					
41						105					
42						106					
43						107					
44						108					
45						109					
46						110					
47						111					
48						112					
49						113					
50						114					
51						115					
52						116					
53						117					
54						118					
55						119					
56						120					
57						121					
58						122					
59						123					
60						124					
61						125					
62						126					
63						127					
64						128					



NISOC

نگهداشت و افزایش تولید میدان نفتی بینک
سطح الارض

احداث ردیف تراکم گاز در ایستگاه جمع آوری بینک



DATA SHEETS FOR ESD CONSOLE/ F&G MATRIX PANEL

شماره پیمان:

۰۵۳ - ۰۷۳ - ۹۱۸۴

پروژه

BK

بسته کاری

GCS

صادرکننده

PEDCO

تسهیلات

120

رشته

IN

نوع مدرک

DT

سریال

0017

نسخه

D02

شماره صفحه: ۳ از ۸

REFERENCE DOCUMENTS :

ESD PHILOSOPHY	BK-GCS-PEDCO-120-PR-PH-0005
I/O LIST FOR ESD SYSTEM	BK-GCS-PEDCO-120-IN-LI-0003
I/O LIST FOR F&G SYSTEM	BK-GCS-PEDCO-120-IN-LI-0004
F&G LOCATION LAYOUT FOR PROCESS AREA	BK-GCS-PEDCO-120-IN-PY-0005
F&G LOCATION LAYOUT FOR BUILDINGS	BK-GCS-PEDCO-120-IN-PY-0006
CAUSE & EFFECT DIAGRAM	BK-GCS-PEDCO-120-PR-CE-0001
F&G CAUSE AND EFFECT DIAGRAM FOR PROCESS AREA	BK-GCS-PEDCO-120-IN-DG-0009
F&G CAUSE AND EFFECT DIAGRAM FOR BUILDINGS	BK-GCS-PEDCO-120-IN-DG-0010
ESD LEVEL HIERARCHY	BK-GCS-PEDCO-120-IN-DG-0003



NISOC

نگهداشت و افزایش تولید میدان نفتی بینک
سطح الارض

احداث ردیف تراکم گاز در ایستگاه جمع آوری بینک



DATA SHEETS FOR ESD CONSOLE/ F&G MATRIX PANEL

شماره پیمان:

۰۵۳ - ۰۷۳ - ۹۱۸۴

پروژه

BK

بسته کاری

GCS

صادر کننده

PEDCO

تسهیلات

120

رشته

IN

نوع مدرک

DT

سریال

0017

نسخه

D02

شماره صفحه: ۴ از ۸

D02

ESD CONSOLE

DIMENSION	ONE PIECE CONSOLE(VTC)
THICKNESS	3MM
NUMBER OF BUTTONS FOR ESD CONSOLE	3 P.B.(spring return) + 11 P.B. (LOCKABLE with protecion cover)
NUMBER OF LAMPS FOR ESD CONSOLE	12 (VTC)
LAMP COLOR FOR ESD CONSOLE	(VTC)
BUTTON TYPE	PUSH BUTTON (P.B.) , LOCKABLE (L.B.) , SELECTOR (S.B.) , COVERED (C.B.), SELECTOR SWITCH 2 POSITION WITH KEY (S.B.2)
INGRESS PROTECTION	IP54
MATERIAL	SHEET STEEL (According to manufacturer/supplier's own standards)
CONSOLE COLOR	RAL 7035
ACCESS	FRONT and REAR (VTC)
CABLE ENTRY	FROM CONSOLE BOTTOM
CONSOLE CONTENT	Audible , PUSH BUTTONS, INDICATING LAMPS and N.I.S. I/O TERMINATION
POWER RANGE	24 VDC

NOTES:

- 1- REQUIRED TERMINALS SHALL BE CONSIDERED TO CONNECT ESD CONSOLE TO ESD SYSTEMS.
- 2- SUITABLE GLAND WITH SPARE PLUGGED CABLE ENTRIES TO BE CONSIDERED.
- 3- PUSH BUTTONS AND LAMPS SHALL BE CONSIDERED.
- 4- 20% SPARE BUTTONS AND LAMPS (NOT CONNECTED) SHALL BE CONSIDERED ON THE CONSOLE.
- 5- SPARE PARTS FOR COMMISSIONING AND 2 YEARS TO BE PROVIDED.
- 6- IN ORDER TO HAVE AUDIBLE ALARM HORN TO BE CONSIDERED .
- 7- IF ANY RELAY, BARRIER AND OTHER DEVICES ARE REQUIRED IN THE ESD CONSOLE, IT SHALL BE SIL3.
- 8- ARRANGMENT OF THE PUSH BUTTONS AND LAMPS SHALL BE BASED ON THE AREAS WHICH THE RELATED DEVICES ARE LOCATED.
- 9- TWO DOORS SHALL BE CONSIDERED FOR EACH FRONT AND REAR ACCESS.
- 10- THE TAG AND DESCRIPTION FOR ALL BUTTONS AND LAMPS SHALL BE PROVIDED. THE MATERIAL OF TAGS SHALL BE S.S. 10 CHARACTERS FOR TAGs AND 32 CHARACTERS FOR DESCRIPTION TO BE CONSIDERED AS A MINIMUM.
- 11- VENDOR SHALL PROVIDE SYMBOL & LEGEND FOR DEVICE USED IN ESD CONSOLE. THIS LEGEND & SYMBOL SHALL BE ADDED TO ALL PANEL LAYOUTS.
- 12- IF ANY ELECTRICAL EQUIPMENT, FAN AND OTHER DEVICES ARE REQUIRED IN THE ESD CONSOLE; SPARE SPACE SHALL BE CONSIDERED ON THE CONSOLE.



NISOC

نگهداشت و افزایش تولید میدان نفتی بینک
سطح الارض

احداث ردیف تراکم گاز در ایستگاه جمع آوری بینک



DATA SHEETS FOR ESD CONSOLE/ F&G MATRIX PANEL

شماره پیمان:

۰۵۳ - ۰۷۳ - ۹۱۸۴

پروژه

BK

بسته کاری

GCS

صادر کننده

PEDCO

تسهیلات

120

رشته

IN

نوع مدرک

DT

سریال

0017

نسخه

D01

شماره صفحه: ۵ از ۸

D02

F&G MATRIX PANEL

DIMENSION	ONE PIECE CONSOLE(VTC)
THICKNESS	3MM
NUMBER OF BUTTONS FOR F&G MATRIX	4 P.B. + 9 P.B.with cover
NUMBER OF LAMPS FOR F&G MATRIX	47 (VTC)
LAMP COLOR FOR F&G MATRIX	RED ,BLUE,YELLOW ,ORANGE
BUTTON TYPE	PUSH BUTTON (P.B.) , LOCKABLE (L.B.) , SELECTOR (S.B.), COVERED (C.B.), SELECTOR SWITCH 2 POSITION WITH KEY (S.B.2)
INGRESS PROTECTION	IP54
MATERIAL	SHEET STEEL (According to manufacturer/supplier's own standards)
CONSOLE COLOR	RAL 7035
ACCESS	FRONT and REAR (VTC)
CABLE ENTRY	FROM CONSOLE BOTTOM
CONSOLE CONTENT	ALARM ANNUNCIATE, PUSH BUTTONS, INDICATING LAMPS and N.I.S. I/O TERMINATION
POWER RANGE	24 VDC
<p>NOTES:</p> <p>2- SUITABLE GLAND WITH SPARE PLUGGED CABLE ENTRIES TO BE CONSIDERED.</p> <p>3- PUSH BUTTONS AND LAMPS SHALL BE CONSIDERED.</p> <p>4- 20% SPARE BUTTONS AND LAMPS (NOT CONNECTED) SHALL BE CONSIDERED ON THE CONSOLE.</p> <p>5- SPARE PARTS FOR COMMISSIONING AND 2 YEARS TO BE PROVIDED.</p> <p>6- IN ORDER TO HAVE AUDIBLE ALARM HORN TO BE CONSIDERED .</p> <p>7- IF ANY RELAY, BARRIER AND OTHER DEVICES ARE REQUIRED IN THE ESD CONSOLE, IT SHALL BE SIL3.</p> <p>8- ARRANGMENT OF THE PUSHBUTTONS AND LAMPS SHALL BE BASED ON THE AREAS WHICH THE RELATED DEVICES ARE LOCATED.</p> <p>9- TWO DOORS SHALL BE CONSIDERED FOR EACH FRONT AND REAR ACCESS.</p> <p>10- THE TAG AND DESCRIPTION FOR ALL BUTTONS AND LAMPS SHALL BE PROVIDED. THE MATERIAL OF TAGS SHALL BE S.S. 10 CHARACTERS FOR TAGs AND 32 CHARACTERS FOR DESCRIPTION TO BE CONSIDERED AS A MINIMUM.</p> <p>11- VENDOR SHALL PROVIDE SYMBOL & LEGEND FOR DEVICE USED IN ESD CONSOLE. THIS LEGEND & SYMBOL SHALL BE ADDED TO ALL PANEL LAYOUTS.</p> <p>12- IF ANY ELECTRICAL EQUIPMENT, FAN AND OTHER DEVICES ARE REQUIRED IN THE F&G MATRIX; SPARE SPACE SHALL BE CONSIDERED ON THE PANEL.</p> <p>13-ALL VISUAL ALARMS SHOULD DISTIGUISH BETWEEN PRE ALARM AND ALARM BY ASSINGING DIFFERENT FREQUENCY ON/OFF LAMP.</p>	



تجهادست و افزایش تولید میدان نفتی بینک
سطح الارض

احداث ردیف تراکم گاز در ایستگاه جمع آوری بینک



DATA SHEETS FOR ESD CONSOLE/ F&G MATRIX PANEL

شماره پیمان:	پروژه	بسته کاری	صادر کننده	تجهیزات	رشته	نوع مدرک	سریال	نسخه	شماره صفحه ۸ از ۱۶
۰۴ - - ۷۲ - ۹۱۸۴	BK	GCS	PEDCO	120	IN	DT	17	D02	

D02

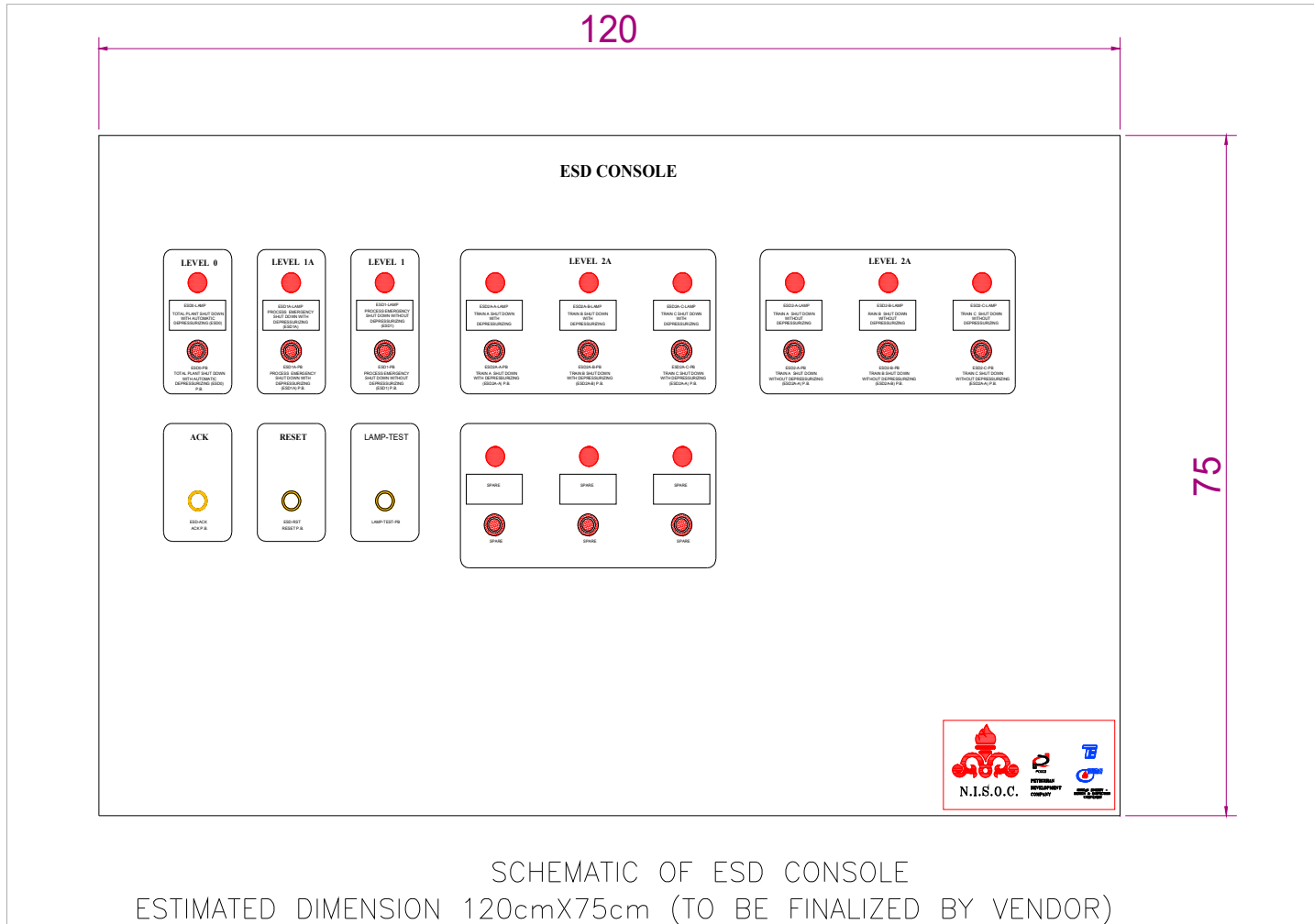



تجهيزات و افزایش تولید میدان نفتی بینک
سطح الارض

احداث ردیف تراکم گاز در ایستگاه جمع آوری بینک

DATA SHEETS FOR ESD CONSOLE/ F&G MATRIX PANEL



شماره صفحه: ۲۲

شماره پیمان:

۰۵۲ - ۷۲ - ۹۱۸۴

پروژه

بسته کاری

صادر کننده

تجهيزات

رشته

نوع مدرک

سریال

نسخه

BK

GCS

PEDCO

120

IN

DT

17

D02

75

120

D02

F&G MATRIX PANEL

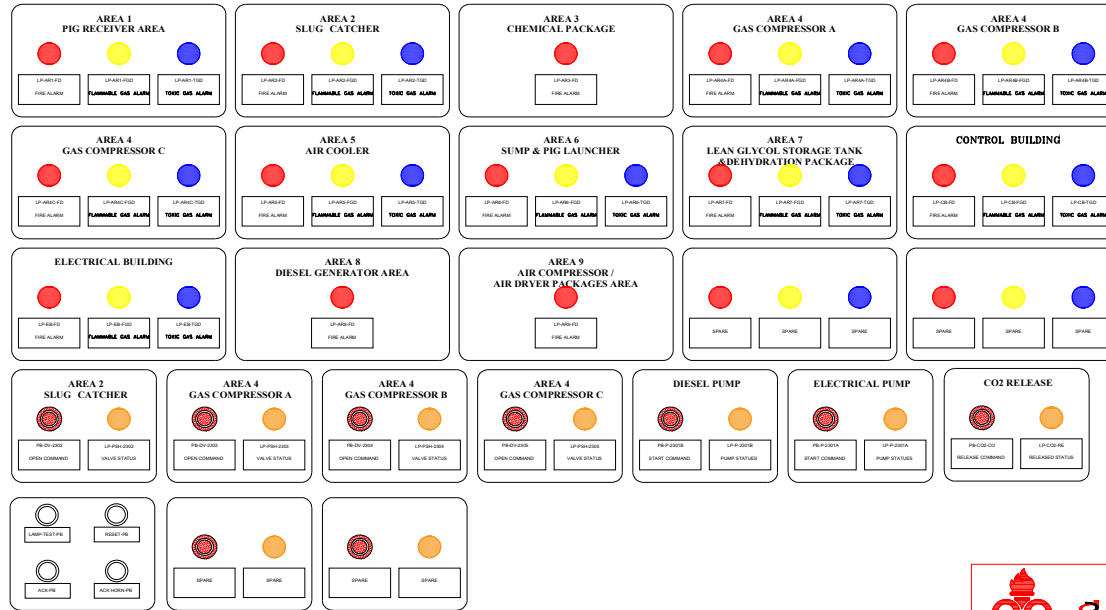

SCHMATIC OF F&G MATRIX PANEL
ESTIMATED DIMENSION 120cmX75cm (TO BE FINALIZED BY VENDOR)



NISOC

تگهداشت و افزايش توليد ميدان نفتي بينک
سطح الارض

احداث ردیف تراکم گاز در ایستگاه جمع آوری بینک

DATA SHEETS FOR ESD CONSOLE/ F&G MATRIX PANEL



شماره صفحه 8 از 8

شماره پیمان:

پروژه

بسته کاری

صادر کننده

تجهیزات

رشته

نوع مدرک

سریال

نسخه

۰۵۴ - - ۷۳ - ۹۱۸۴

BK

GCS

PEDCO

120

IN

DT

17

D02

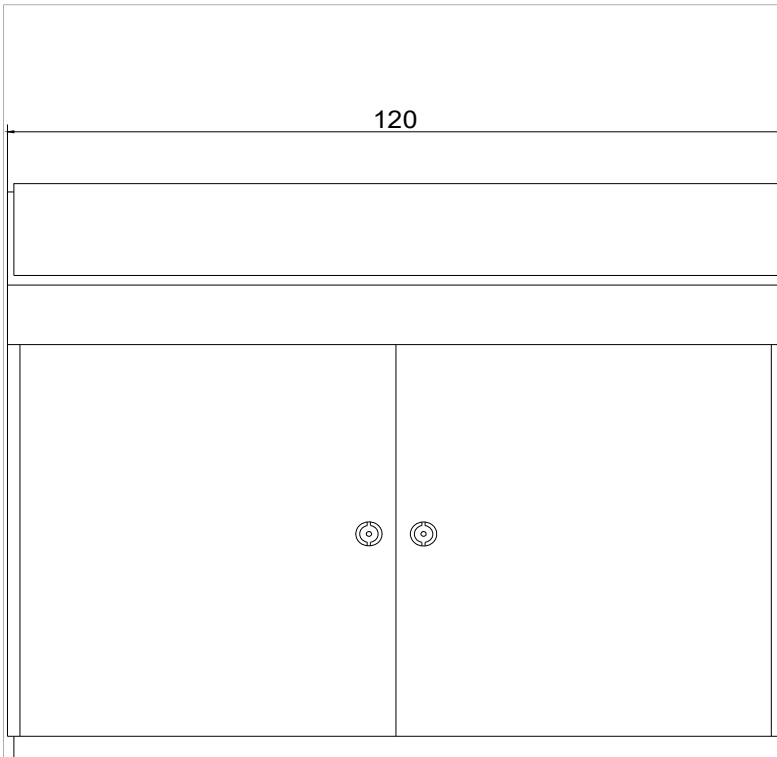

FRONT VIEW OF PANEL (TO BE FINALIZED BY VENDOR)
ESD CONSOLE AND F&G CONSOLE HAVE SAME SEDIGN

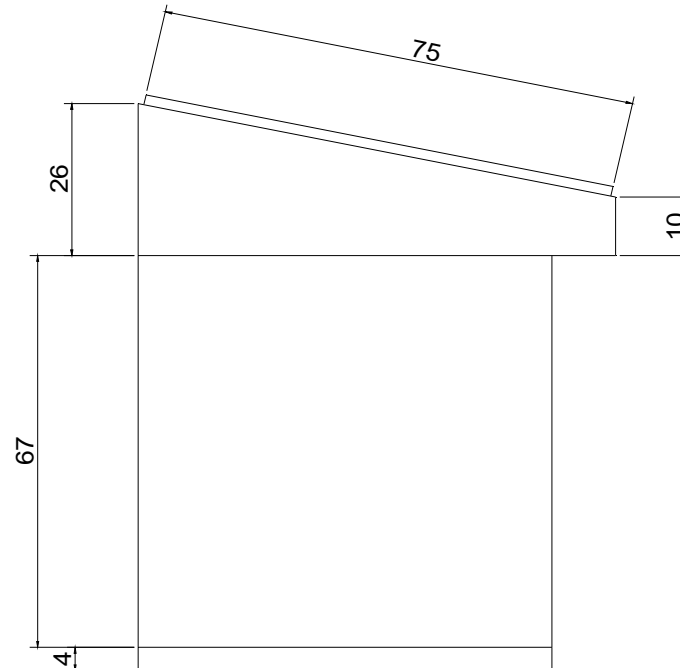

SIDE VIEW OF PANEL (TO BE FINALIZED BY VENDOR)
ESD CONSOLE AND F&G CONSOLE HAVE SAME SEDIGN

D02