

**NOTES**

- 1) ALL DIMENSIONS ARE IN "mm" AND EXPANSION IN "mm" UNLESS SPECIFIED.
- 2) ALL DIMENSIONS AND ELEVATIONS SHALL BE CHECKED BY THE CONTRACTOR PRIOR TO CONSTRUCTION.
- 3) CONTRACTOR SHALL CHECK THE ARCHITECTURAL DRAWING WITH ALL STRUCTURAL, MECHANICAL, ELECTRICAL, PLUMBING & SANITARY DRAWINGS FOR CONSTRUCTION AND ANY REQUIRED MODIFICATIONS SHALL BE CONSIDERED WITH PROJECT CLIENT APPROVAL BEFORE CONSTRUCTION.
- 4) AT ALL THE SHEET TOP OF CONCRETE LEVEL SHOULD BE +0.10m ABOVE H.P.C.
- 5) THERE ARE SEVERAL FIRE SHEETS IN THE SITE FOR NORTH DIRECTION AND COMPONENTS. SEE RELATED PLOT PLAN DRAWING.

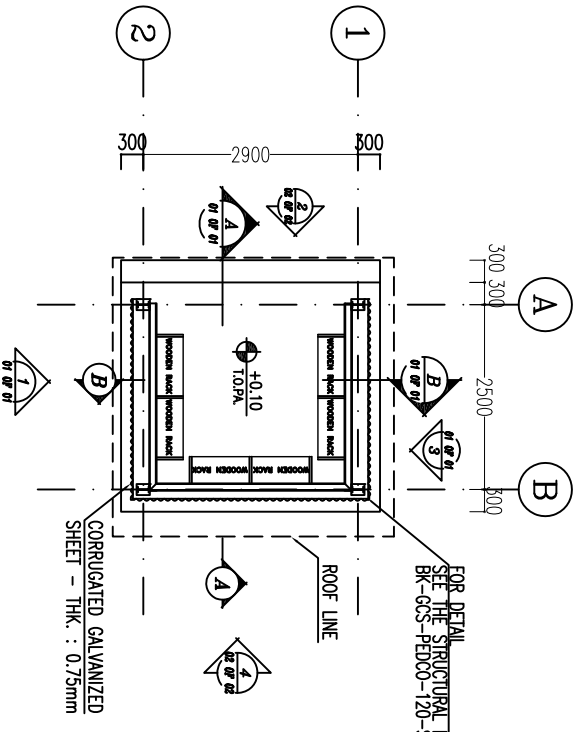

SC.1:50 1 GROUND FLOOR PLAN

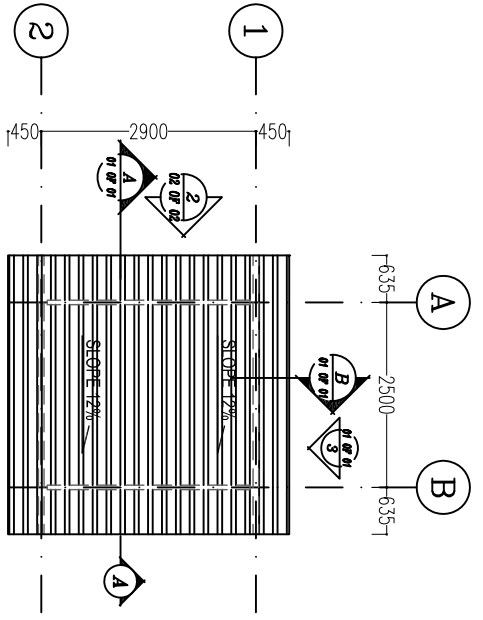

SC.1:50 2 ROOF PLAN

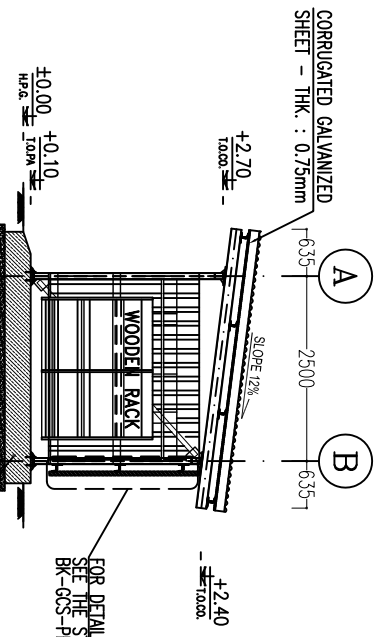

SC.1:50 SECTION A-A

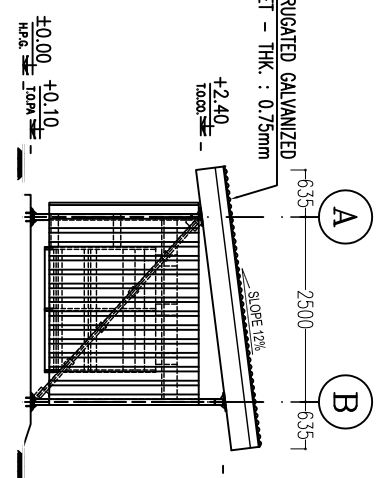

SC.1:50 SECTION B-B

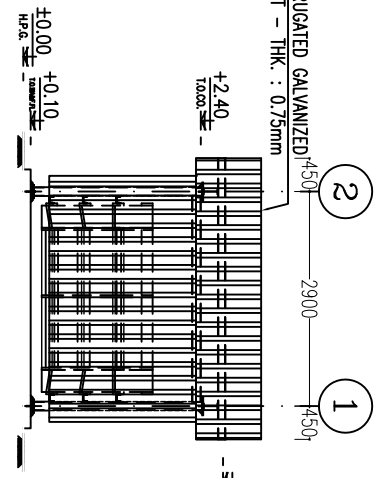

SC.1:50 SECTION C-C

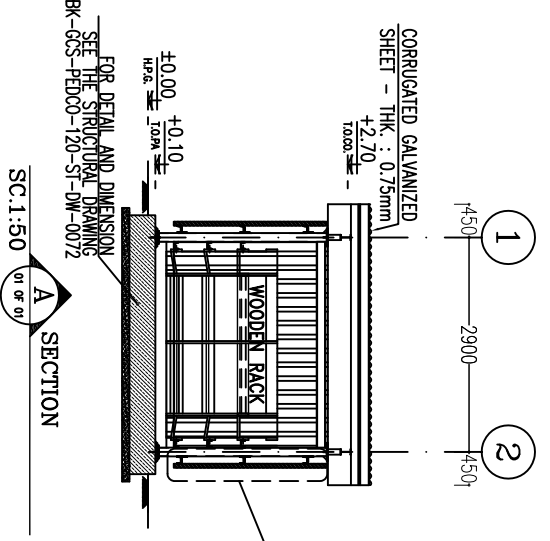

SC.1:50 ELEVATION 1

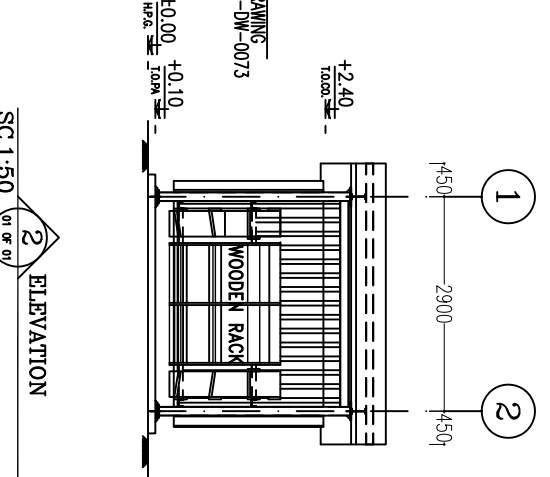

SC.1:50 ELEVATION 2

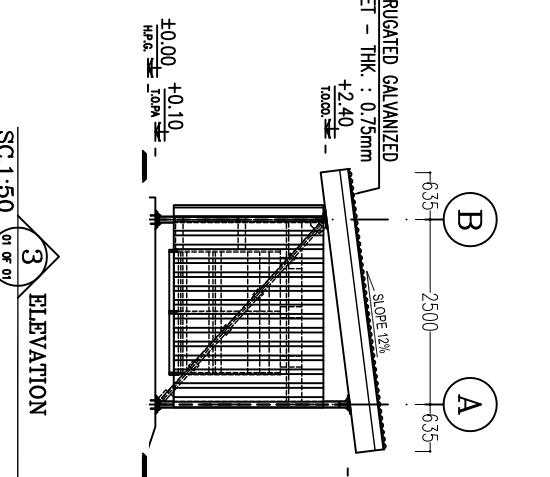

SC.1:50 ELEVATION 3

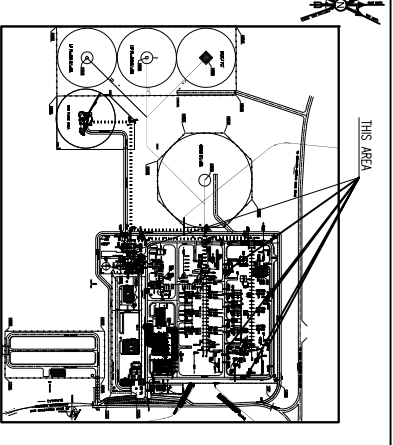

KEY PLAN

**LEGEND**

CORRUGATED METAL SHEET THK. = 0.75mm	
--------------------------------------	--

**REFERENCE DRAWING**

NO.	DESCRIPTION	DATE	NO.	DESCRIPTION	DATE
1	ROOF PLAN	12-01-2023	1	ROOF PLAN	12-01-2023
2	GROUND FLOOR PLAN	12-01-2023	2	GROUND FLOOR PLAN	12-01-2023
3	SECTION A-A	12-01-2023	3	SECTION A-A	12-01-2023
4	SECTION B-B	12-01-2023	4	SECTION B-B	12-01-2023
5	SECTION C-C	12-01-2023	5	SECTION C-C	12-01-2023
6	ELEVATION 1	12-01-2023	6	ELEVATION 1	12-01-2023
7	ELEVATION 2	12-01-2023	7	ELEVATION 2	12-01-2023
8	ELEVATION 3	12-01-2023	8	ELEVATION 3	12-01-2023
9	KEY PLAN	12-01-2023	9	KEY PLAN	12-01-2023

NO.	DATE	BY	CHK.	APP.	AUT.
001	12-01-2023	ABC	DEF	GHI	JKL
002	12-01-2023	ABC	DEF	GHI	JKL
003	12-01-2023	ABC	DEF	GHI	JKL
004	12-01-2023	ABC	DEF	GHI	JKL

PROJECT NO.:	971000
PROJECT NAME:	BIHAK OILFIELD DEVELOPMENT/SURFACE FACILITIES GAS COMPRESSOR STATION
EPG CONTRACTOR:	IRISGAN
EPD/EPIC CONTRACTOR (GC):	PETROBRAS DEVELOPMENT COMPANY
IRISGAN ENGINEER - DESIGN & INSPECTION:	TE
IRISGAN ENGINEER - COMPARISON:	PDCCO
DRAWING TITLE:	ARCHITECTURAL DRAWING FOR PFB SHEED
SCALE:	AS SHOWN
AS SHOWN:	AI

NO CONSTRUCTION PERMITTED UNLESS DRAWING APPROVED	APPROVED FOR CONSTRUCTION BY:	DATE:
REVISION	SERIAL NO.	DATE
1	1	12-01-2023
2	2	12-01-2023
3	3	12-01-2023
4	4	12-01-2023
5	5	12-01-2023